

**Note:**

If your lock is opening on every turn of the knob or lever, except upon entering a code, this may be a ZERO CODE. Before attempting to remove the lock from the door, refer to the troubleshooting procedures outlined at bottom of this document for a zero code symptom/solution.

**7000 Series FAQ****Changing the Code / Combination**

**Important:** The following steps must be performed while the door is open.

The factory pre-set combination is 2 and 4 pressed simultaneously and released, then press 3 and release.

Read the instructions through once before attempting to change the combination.

1. Turn the outside thumbturn to the left (counterclockwise) until it stops then return it to the right (clockwise) slowly to the horizontal position and release.

2. Enter the existing combination.

3. Insert a Phillips-head screwdriver into the central piece of the combination change assembly (see figure 1). Gently turn the screwdriver to the right (clockwise) until it stops. A slight click should be felt. Do not force.

4. Remove the screwdriver from the combination change assembly.

Important: When removing the screwdriver, the central piece must return to its initial position, if not, set it back to its original position using the screwdriver (see Figure 1). If the central piece of the combination change assembly does not return to its original position, the combination will be cancelled and the lock will jam.

5. Turn the outside thumbturn to the left (counterclockwise) until it stops and return it slowly to the right (clockwise) to the horizontal position and release.

This clears the existing code (see figure 2).

6. Select a new combination and write it down. Some or all of the buttons may be used for your new code, pressed individually or simultaneously. Each button may be used only once. We do not recommend the use of a one-button combination.

7. With the door open, enter your new combination. Depress each button fully and release it. You must feel a click each time you press a button to know that the button was fully depressed.

8. Turn the outside thumbturn to the right (clockwise) until it stops; the latch/bolt should retract.

9. For automatic relocking latches, release the outside thumbturn and the latch should return to its initial extended position.

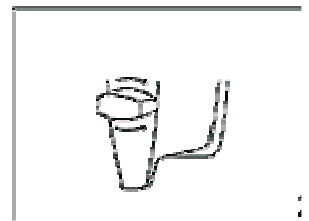
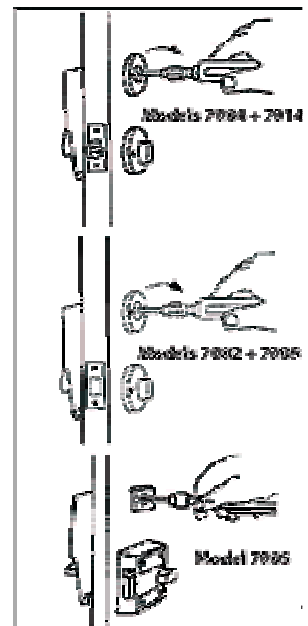

45 Assembly Street Edinburgh EH6 7BQ  
Tel: 0131 555 0909 Fax: 0131 554 1177  
Email: sales@keyprint.co.uk  
Website: [www.keyprint.co.uk](http://www.keyprint.co.uk)

For manual relocking deadbolts, turn the outside thumbturn to the left (counterclockwise) until it stops; the bolt should extend.

Keep the door open and test the operation of the lock 2-3 times to make sure your combination was set correctly.

**Note:**

- Do not use excessive force at any time.
- If a wrong combination is entered while operating the lock, turn the outside thumbturn to the left (counterclockwise) to the top position and release. (see Figure 2). This will clear any previously depressed buttons. Enter in the correct combination.

**Troubleshooting**

**Symptom / Problem:** Turning outside thumbturn clockwise always retracts latch without depressing any buttons.

**Cause:** Lock is in zero combination.

**Solution:** Follow the procedure for setting a new combination except omit step 2.